

BCLS Certificate Example

BC Land Surveyor's Building Location Certificate On:
 Lot 1, Section 2, Range 3 East, Victoria District, Plan 12345.
 (P.I.D. No. 123-456-789)

This document was prepared for mortgage and municipal purposes and is for the exclusive use of our client, John Smith.

This document shows the relative location of the surveyed structures and features with respect to the boundaries of the parcel described above. This document shall not be used to define property lines or property corners.

The signatory accepts no responsibility or liability for any damages that may be suffered by a third party as a result of any decisions made, or actions taken based on this document.



Scale = 1:250

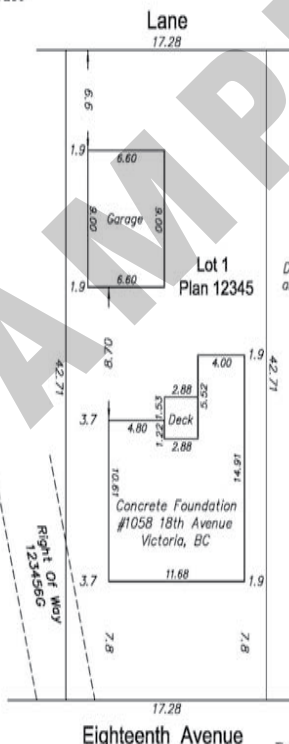

Lane
17.28

Garage
6.60 x 8.00

Deck
4.80 x 2.88

Concrete Foundation
#1058 18th Avenue
Victoria, BC
11.68 x 14.91

Right of Way
123456G

Eighteenth Avenue
17.28

Distances shown are in metres and derived from Plan 12345.

The subject property is affected by the following registered documents:
 123456G, FH456789, FV192837.

Certified Correct this ___ day of ___, 2008.

B.C.L.S. (Not valid unless originally signed & sealed)

© ALL RIGHTS RESERVED

ABCLS Land Surveying Inc.
 #301-2400 Bevan Avenue
 Sidney, BC V8L 1W1
 Telephone (250) 655-7222
 File: ABCLS CERT

Helping you make an informed decision



Association of BC Land Surveyors
 #301 - 2400 Bevan Avenue
 Sidney, BC V8L 1W1
 PH 250-655-7222
 FAX 250-655-7223

An Information Guide

**Building Location Surveys &
Certificates and Title Insurance
in British Columbia**



**British Columbia
Land Surveyors**
www.abcls.ca





PROFESSIONALISM HISTORY TECHNOLOGY

Building Location Surveys

A Building Location Survey is...

- Based on an actual site inspection and measurements by qualified personnel.
- Simple to read and understand.
- A plan view of your property showing the boundaries according to the plan or legal description your title is based on.
- A graphical sketch showing the locations of buildings, other improvements, easements, rights-of-way, covenants and other interests on the property in relation to boundaries.

The benefits of a Building Location Survey include...

- Disclosure of encroachments.
- Clear depiction of any problems relating to encroachments or building locations that may need to be resolved before completing a purchase and information to determine if buildings meet local zoning with respect to setbacks.
- Use for a range of preliminary planning options, from potential building additions and improvements to determining if further subdivision may be possible.

Building Location Surveys have been widely and commonly used for over forty years in BC. The survey document is titled a "Building Location Certificate" and certified correct by a BC Land Surveyor. They are an integral part of a real estate transaction when provided to your lawyer or notary

public, however they retain a lasting usefulness to the property owner as both a record of the state of the property and as a planning tool.

Title Insurance in British Columbia

Title Insurance...

- Is a complex legal insurance policy.
- Requires separate policies to protect the owner and the lender.
- May not, except at added cost, protect anything but the amount of the mortgage (leaving the remaining cost of resolving problems to the owner).
- Where the policy is a lender policy, it is only in effect as long as that lender has an interest in the property.
- Is a product developed in the United States to protect mortgagees from hidden interests in property. It was developed as a result of inadequate deed registry systems and the somewhat unorganized manner in which lands were occupied for settlement. It has become virtually impossible to obtain a mortgage in the US without buying a title insurance policy to protect the lender.

British Columbia's Land Title System

The Land Title system in BC guarantees title against fraud through a legislated publicly funded insurance program, known as the Assurance Fund.

Your Choices

Purchasers are being advised that the cost of a survey can be avoided by the purchase, at a lower cost, of title insurance. The inference is that title insurance offers greater value at a lower cost. This is unfortunate, because title insurance does not provide any information about the location of buildings, improvements, easements, rights of way, covenants and other interests in relation to the property boundaries to an owner or lender. A current survey effectively discloses problems, should they exist, to all interested parties who can then take appropriate action for resolution.

A British Columbia land surveyor's Building Location Certificate is a wise marketing tool for a vendor and provides valuable information for a purchaser or mortgagor.

Significant financial commitments should not be made without full knowledge of all relevant facts, potential liabilities and inherent risks in the venture. For this reason the Association of British Columbia Land Surveyors encourages you to use a traditional system of "full disclosure", through the use of proper title review and a surveyed building location before committing to an investment in real estate.

Lender and/or purchaser insurance may well have a place in real estate transactions, especially those involving complicated land assemblies and financing. It should be viewed as complementary to the traditional process of investigation of quality and extent of title, rather than as an alternative.